

Power Maximization of a PV-Wind HRES via DC-link Voltage Boosting

Marco Beccali¹, Massimiliano Luna¹, Marcello Pucci² and Gianpaolo Vitale²

¹ D.R.E.A.M. – Dipartimento di Ricerche Energetiche e Ambientali
 Università degli Studi di Palermo. Viale delle Scienze, Edificio 9. 90128 Palermo. Italy.
 phone: +39091236012; fax: +39091484425; email: marco.beccali@dream.unipa.it, luna@dream.unipa.it

² I.S.S.I.A.-C.N.R. Section of Palermo (Institute on Intelligent Systems for the Automation)
 via Dante n. 12 90141 Palermo, Italy. Email: marcello.pucci@ieee.org, gianpaolo.vitale@ieee.org

Abstract. This paper describes a method for the optimization of a Hybrid Renewable Energy System applied to a low power PV-Wind plant. The goodness of the methodology is firstly proved by means of a novel graphical technique and then verified with a series of numerical simulations. The results are discussed and show that, adopting the proposed technique, a significative increase in the generated power and in the annual energy produced can be achieved.

Key Words: HRES, PV-wind, optimization, maximum power, DC/DC converter, voltage boost.

1. Introduction

A Hybrid Renewable Energy System (HRES) is a system aimed at the production and utilization of the electrical energy coming from more than one source, provided that at least one of them is renewable. In a conventional low power stand-alone renewable system, the storage device, e.g. the battery, is connected directly to the DC-link, together with the charge regulator(s) of the generator(s) and the input stage of the inverter. These charge regulators are often DC/DC converters operated with the PWM (Pulse Width Modulation) technique.

A novel graphical construction on the I-V plane is proposed, which allows to evaluate the operating points involved in the PWM for an assigned operating condition, thus forecasting the behaviour of the system.

The graphical analysis shows that the DC-link voltage is very close to the battery e.m.f. and, thus, far from the MPP (Maximum Power Point) voltage of the generator(s). Hence, the power production can be maximized if the DC-link voltage is properly boosted. This relationship between the DC-link voltage level and the produced power extends the conclusions in [1], since the limits to the voltage increase are discussed and because hybrid systems are also considered.

2. Discussion

Figure 1 shows the graphical analysis for a PV non hybrid system which employs a PWM DC/DC buck charge regulator. The red line is the load characteristic, while the green dashed line is related to the “battery and load” set. The vertical blue line is the DC-link voltage. It is possible to find the load operating point (point P if no battery is used) and the points P₁ and P₂.

The operating point of the generator moves from P₀ to P₁ as the PWM is performed, and P₂ is the average operating point.

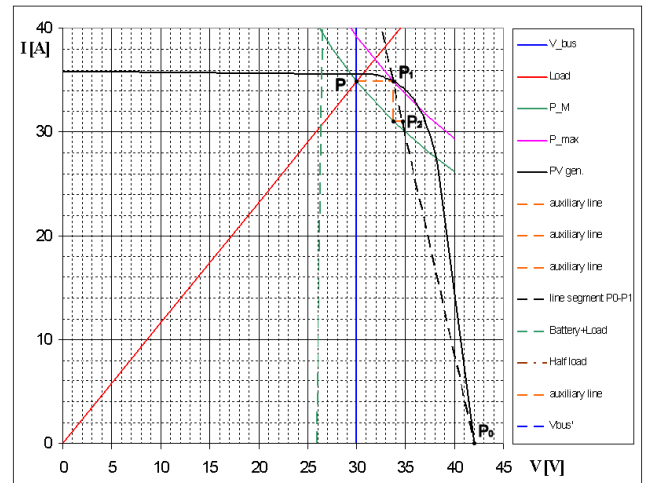

Fig. 1. Graphical analysis for a PV system, with or without a battery, with constant DC-link voltage

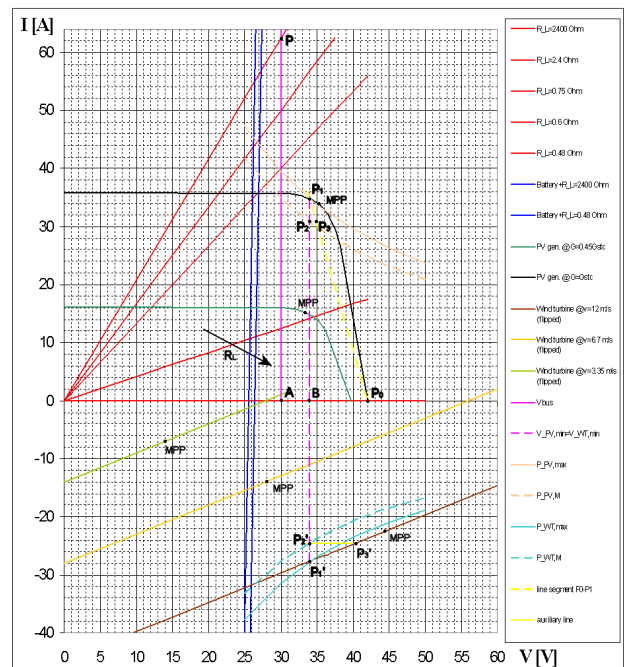

Fig. 2. Graphical analysis for a PV-wind HRES connected to a load, with or without a battery, with constant DC-link voltage

The system is stable in all operating points (reached in a brief transient) except for some severe overload conditions.

If a battery is used, the green dashed line should be considered, instead of the red one. Since the ratio between the voltages of points P and P₁ equals the duty-

cycle d , it should be limited to a proper value (d_{max}) to prevent the stall of the converter. The same relationship applies to the power (green and purple hyperboles). Therefore, it is shown that the utilization of PWM converters, which are indeed necessary, doesn't allow to operate each source in its true MPP.

Non linear sources, e.g. PV generators, exhibit a MPP voltage which is nearly constant with the operating conditions. As a matter of fact, for generators with a linear characteristic, such as a P.M. brushless wind turbine, a correct matching cannot be achieved. Figure 2 shows the graphical analysis for a PV-wind HRES. According to different operating conditions, two characteristics are drawn for the PV generator and three for the wind turbine (light green, yellow, brown). The latter are flipped along the horizontal axis. It is shown that a HRES can be operated at its maximum deliverable power when every duty-cycle is set at d_{max} and the DC-link voltage is kept in the range between the two MPP voltages and closer to the one related to a higher power. Moreover, the maximum deliverable power is lower or equal to the product of d_{max} multiplied by the sum of the maximum powers of the generators, and the deviation from this quantity depends on the proximity of the two MPP voltages.

3. System design

The previous considerations entail a matching between the chosen DC-link voltage, the prevalent generator, the storage system and the limit to the load voltage. Therefore, after presenting the state of the art of HRESs [2], a new combination of circuit topology and control technique is proposed.

The chosen topology is the VSI multistring inverter, coupled with a series of DC/DC buck converters for the generators and a buck/boost one for the storage device (figure 3). The latter converter allows to step-up the battery voltage during the discharge on the DC-link and to step it down during the charge operation.

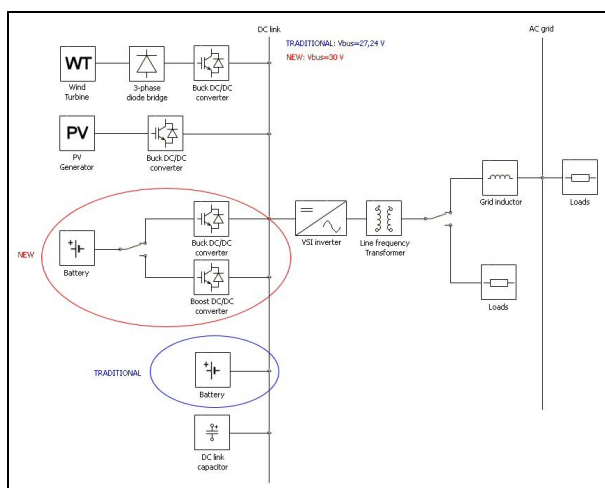

Fig. 3. Traditional and new circuit topologies

All the converters are controlled by PID regulators designed with traditional methods [3], to maintain the DC link voltage constant and equal to the highest possible value, respecting the previously discussed limits. The

grid-connected operation cannot be further optimized but it is kept similar to the traditional configuration. Moreover, it is possible to unify both the circuit topology and the HW/SW required for controlling the converters in the stand-alone and grid-connected operation. The proposed solution has been verified by simulating the system with Simulink and PLECS in several scenarios which use real data coming from an existing 2.2 kW_p PV-Wind-battery system, set-up at D.R.E.AM. [4].

4. Simulation results

The results have been analysed and they confirm that in the stand-alone operation a significant increase in the power supplied can be achieved, up to 13.73% according to the operating conditions of the generators and to the load power level (fig. 4). This also implies a higher continuity of the energy supplied to the load. As to the annual energy produced, an analysis on the basis of a one-year campaign of sun and wind data monitoring has been performed, which shows an increase between 4% and 5.5% for two typical load resistance values in the stand-alone configuration. It shows also a non perfect fit with the typical data given by the manufacturers for the grid-connected operation.

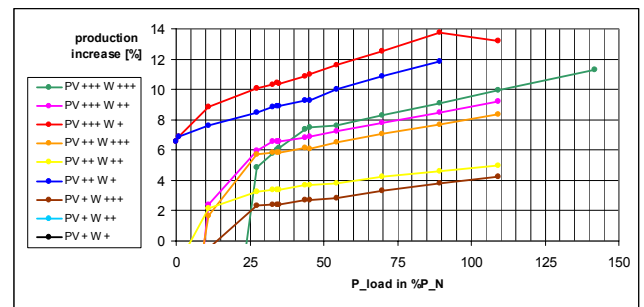

Fig. 4. Production increase versus load power level in several operating conditions for solar radiance and wind speed: +++=maximum, ++=average, +=minimum

5. Conclusions

Using a buck/boost converter to interface the storage device to the DC link allows a significant increase in the power supplied by the renewable sources, thus maximizing the operating efficiency. Also the annual energy produced by the whole system increases. Finally, a non perfect fit with the typical data given by the manufacturers has been shown.

References

- [1] D. Shmilovitz. "On the control of photovoltaic maximum power point tracker via output parameters". IEE Proc.-Electr. Power Appl. Vol. 152, No. 2. March 2005.
- [2] M.K. Deshmukh, S.S. Deshmukh. "Modeling of hybrid renewable energy systems". Renewable and Sustainable Energy Reviews. 12 (2008) 235-249.
- [3] R. W. Erickson, D. Maksimovic. "Fundamentals of Power Electronics, 2nd ed.". Kluwer Academic Publishers. 2003.
- [4] M. Beccali, M. Luna, M. Pucci, G. Vitale. "Experimental Analysis of Power Quality Issues in a Mobile House supplied by Renewable Energy Sources". International Conference on Renewable Energies and Power Quality (ICREPQ'07). 28-30 March, 2007. Sevilla, Spain.