

# Distortion Sources Identification in Electric Power Systems

R. S. Herrera, A. Pérez, P. Salmerón, J. R. Vázquez, S. P. Litrán

Department of Electrical Engineering  
E.P.S., Huelva University

Ctra. Huelva-Palos de la Frontera, s/n – Palos de la Frontera, 21819 Huelva (Spain)

phone:+34959217572, fax:+34959217304,

e-mail: reyes.sanchez@die.uhu.es, aperez@uhu.es, patricio@uhu.es, vazquez@uhu.es, salvador@uhu.es

**Abstract.** Distorted voltage and current waveforms is one of the problems associated to electric power quality. Continuous use of non-linear loads provokes the existence of voltage waveforms with a high distortion. Thus, it is necessary to know the responsible of this problem by means of the commonly named distortion sources identification. In this paper, the problem is analyzed through the harmonic power sign, with the objective of knowing the sense of harmonic power flow between source and one load in distorted systems. Nowadays, it has already been established in the Literature that an analysis of this kind does not solve the problem. Recently, new indices have been introduced to evaluate a specific consumer distortion level. In this paper, a comparative analysis of these indices is carried out, having as reference a practical case. The results obtained show that, in fact, these indices can help to value the harmonic distortion, although none of them solve the question definitively.

**Key words:** Power Quality, Harmonic, Distortion Indices, Measurements.

## 1. Introduction

Many problems of electric distribution system are derived from harmonic distortion. If voltage and current waveforms are distorted, it is important to identify the distortion sources. The correct identification is essential due to two factors. On the one hand, it allows the effective design of most appropriate harmonic mitigation equipment. On the other hand, it achieves the establishment of the responsibility of each implied agent, consumers or manufacturers.

A lot of works have been published up now about valuation and location of distortion sources in electrical systems, [1-11]. Two different approaches can be distinguished: a) those based on measurements taken on the point of common coupling PCC, knowing or not the net/consumer impedance, b) those based on measurements taken on different points of the power system, using mainly state estimation techniques, [12-13]. This paper is developed within the first group. Different methods have been proposed, among others: 1) the method of harmonic power flux sense, [4,7,10,14], 2) the superposition and projection method, SPM, [15]-[17], 3) the connection and disconnection method to detect one

load harmonic level, [18], 4) the critical impedance method, CIM, [19], and 5) hybrid methods that carry out an estimation of the parameters of an equivalent linear load through measurements on the PCC, [20]-[22].

Method 1) may be considered as the most usual. The harmonic power flux sense (net-consumer) establishes the agent who presents the greatest harmonic distortion in the measurement point. This method has been used in the industry as a confinable procedure that is the origin of several indices as THD (Total Harmonic Distortion). Besides, they have been included in commercial analyzers as a key characteristic of the product, [14]. Nevertheless, in [16] clear clues have been established which prove that the method is not adequate to evaluate the distortion emissions. In that work method 2) is proposed, SPM, and later the same authors developed in [19] method 4), CIM. All these procedures are based on the use of a Norton model to represent the harmonic equivalent circuit. The analysis is carried out from the parameters value and harmonic current sources of the Norton equivalent to find the relationship between harmonic impedance and harmonic voltage source from measurements in PCC, [18]. Certainly, this kind of methods can detect the side that contributes to the distortion in a higher level to PCC. Nevertheless, these procedures require the knowing of net/consumer harmonic impedances. Method 3) established the harmonic emission levels through the consumer connection/disconnection or through an auxiliary element shunt connection/disconnection. All these methods present advantages and disadvantages. In general they require the exact knowing of net and consumer Norton models corresponding to each harmonic. Besides, their results are valid only in the measurement instant.

Method 5) is based on measurements made in PCC. Its objective is the establishment of finding out the part of a specific consumer which is non distorter, proposing the solution of the distortion source location in a simple way and using only commercial analyzers.

Initially, this paper establishes the nature of the problem of harmonic sources detection to analyze the foundation of harmonic power flow sense method. After that, hybrid methods are presented introducing some indices that

allow a comparative analysis of different propositions. Finally, a practical case is presented to illustrate the situation.

## 2. Harmonic power analysis

In a first approximation to the problem, balanced three-phase systems are considered with several non-linear loads connected to PCC. Figure 1 shows the equivalent single-phase circuit, which includes  $n+1$  branches,  $n$  corresponding to the loads and 1 to the source. The net is represented by the Thevenin circuit constituted by a voltage source  $V_s$  in series with impedance  $Z_s$ . Certainly, PCC in figure 1 represents an industrial distribution system.

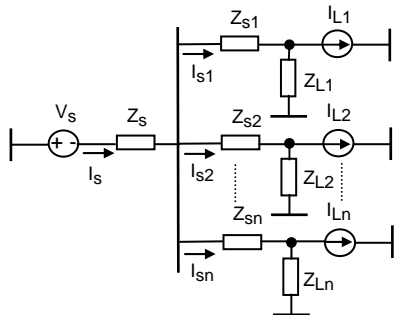

Fig. 1. Balanced three-phase system equivalent circuit

Consumers are supplied by single impedances. Each load is modelled as an impedance  $Z_{Lj}$  connected in parallel to a harmonic source  $I_{Lj}$  where  $j$  is the branch index. Due to the system topology, it is necessary the measurement of voltage and current in each branch connected to the PCC. From these measurements, the consumers responsible of distortion are established. Besides, distortion generated by each one is quantified. Thus, figure 1 can be reduced to figure 2.

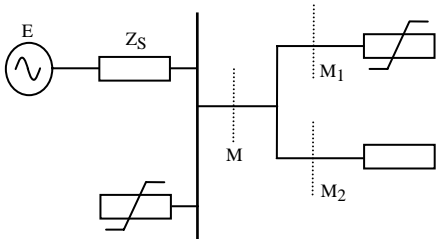

Fig. 2. Power system simplified diagram from its PCC

From now on, diagram presented in figure 2 is considered as reference. There is a point of common coupling, PCC, where a sinusoidal voltage source is connected  $E$  through a source impedance  $Z_s$ . Besides, several linear and non-linear consumers are connected. Measurements taken on  $M$ ,  $M_1$  and  $M_2$  are considered.

A non-linear load (through measurer  $M_1$ ) and a linear load (through measurer  $M_2$ ) are connected to  $M$ . Voltage in  $M$  is non-sinusoidal due to the simultaneous effects of distorted caused by non-linear loads under  $M$  and upper  $M$ .

The analysis of power systems which include non-linear loads can be carried out considering two unknown subsystems. There is a power flux between them corresponding to each harmonic, [7]. The system analysis in frequency domain needs the consideration of an equivalent circuit for each relevant harmonic. Thus, the system is simplified through its Thevenin equivalent circuit from the measurement point: a non-sinusoidal Thevenin voltage and a Thevenin equivalent impedance which depends on frequency. In general, there are harmonics common to Thevenin voltage and current incoming non-linear loads. So, for each common harmonic there is a harmonic active power value corresponding to net and consumer. Its sign depends on the element responsible of the main contribution. According to this, a harmonic analysis can not identify the distortion sources from the active powers addition, but it only can identify the source which presents the main contribution. It is because harmonic currents as harmonic powers are due to the addition of two opposite contributions. Nevertheless, harmonic active and reactive powers measurements were the approach mainly adopted to identify the oscillations introduced by the consumer to the supply waveform quality, [1]-[7], [10]-[11].

### A. An index to identify distorted loads

The analysis presented in previous section suggests the necessity of finding an index which allows the evaluation of oscillations introduced by a specific load in the supply voltage system. At the beginning, an index based on the measurements of harmonic active powers corresponding to each load was proposed. Several propositions within this approach have appeared in last years. Among them, the harmonic phase index,  $\xi_{HPI}$ , [13], defined as follows. A  $3n$  current vector  $I$  is introduced where  $n$  is the maximum harmonic order considered. Vector  $I$  is built with rms values of each phase of each harmonic load current. Vector  $I$  is decomposed in two components  $I_S$  and  $I_L$  whose elements corresponding to each harmonic are defined as follows:

$$I_{Sk} = \begin{cases} 0 & \text{if } P_k \leq 0 \\ I_k & \text{if } P_k > 0 \end{cases} \quad (1)$$

$$I_{Lk} = \begin{cases} 0 & \text{if } P_k \geq 0 \\ I_k & \text{if } P_k < 0 \end{cases}$$

The harmonic phase index introduced in this paper is lightly different from the presented in [13]:

$$\xi_{HPI} = \frac{\|I_L\|}{\|I_S\|} 100 \quad (2)$$

This index has two advantages for the objective followed in its introduction. On the one hand, it is defined from the ratio of current rms values that are the actual cause of disturbances introduced by loads in the net. On the other hand, different harmonic values are not added, but in

quadratic way. It avoids mutual elimination between different harmonics.

### B. Distorted and non-distorted currents

In a paper published in 1996, Srinivasan distinguishes two kinds of loads, deforming loads and non-deforming loads, [8]. A non-deforming load does not cause a change in voltage waveform distortion. Any other load that changes the voltage waveform is a deforming load. Thus, from the harmonic point of view, Srinivasan considers that a non-deforming load presents the same impedance to all the frequencies. A typical load will be constituted by a non-deforming part and a deforming part which may be modelled in a simple way by means of two parallel elements. Current measured in the input  $i(t)$  will be the sum of currents incoming to the non-deforming part  $i_n(t)$  and to the deforming part  $i_d(t)$ . In frequency domain the component of the current obtained as a complex ratio, constant to all the frequencies, multiplied by voltage is the wished part of the incoming current, the part of current demanded by non-deforming part of load. The rest of current is the non wished part of current, the incoming in deforming load. The decomposition of power flux is obtained from the decomposition established by the current.

This approach presented by Srinivasan is directly related to the distortion power analysis carried out by Czarnecki, [24]. In his proposition, Srinivasan actually defines the non-deforming current according to the conditions required by DB to be null. Nevertheless, in his paper discussion published in 1996, [8], and in his later paper with Jutras, [25], it is defined in a definitive way, the non-deforming current (conforming in his development) as the component which does not distort the voltage waveform in the sense of Czarnecki, i.e., the part of the current collinear to the voltage. Thus, non-deforming current is the part of the current that presents the same distortion level as voltage.

Voltage and current measured in load terminals are expressed as the addition of fundamental harmonic voltages and currents and other components multiple of this. The non-deforming current presents the same variation as voltage waveform and its phase may be lower or higher. On the other hand, due to the fact that the load can not generate power at fundamental frequency, non-deforming current evolves the complete active and reactive power at fundamental frequency. Non-deforming current at fundamental frequency  $I_{n1}$  is equal to the total current at fundamental frequency  $I_1$ . The rest of the components corresponding to the non-deforming current different frequencies are proportional to voltage harmonic components. The proportional constant is:

$$\begin{aligned} \mathbf{Y}(jk\omega_1) &= |\mathbf{Y}(j\omega_1)| k(\phi_1 - \theta_1) \\ \mathbf{Y}(j\omega_1) &= \left| \frac{\mathbf{I}_1}{\mathbf{V}_1} \right| (\phi_1 - \theta_1) \end{aligned} \quad (3)$$

Expressions in time domain for each phase current are:

$$\begin{aligned} i_n(t) &= \sum_{k=1}^n \frac{I_1}{V_1} \sqrt{2} V_k \sin(k\omega_1 t + \theta_k + k(\phi_1 - \theta_1)) \\ i_d(t) &= i(t) - i_n(t) \end{aligned} \quad (4)$$

where  $V_1$  and  $I_1$  are fundamental voltage and current rms values in PCC,  $\theta_1$  and  $\phi_1$  are voltage and current phase,  $\theta_k$  is voltage order  $k$  harmonic phase and  $i(t)$  is the load current. The index proposed by Srinivasan is the non collinear index NC:

$$NC = \frac{I_d}{I} 100 \quad (5)$$

where  $I_d$  is  $i_d(t)$  rms value.

### C. Distorted and non-distorted currents

The problem of differencing supply and consumer contributions to the distortion was boarded by Dell'Aquila et al. in a paper in 2004 where they analyzed this problem as go on, [23]. The dismissing of electric power quality due to harmonics can be caused simultaneously in several point of the net. Voltage and current waveforms measured in PCC are due to the combined effect of several polluting equipment connected in different places in the net. Thus, it is not possible locate the source of this problem. However, it is possible the determination of the studied load contribution to harmonic distortion, whereas the rest is considered to be from supply side which includes the rest of loads. The first step to propose some indices which allow the valuation of the contribution to harmonic distortion is fixing the ideal load conditions. Any load which shows a linear and balanced behaviour represents an ideal load condition. In fact, if studied load is balanced and linear, the supply system is the only responsible of harmonic distortion in PCC. Initially, it is necessary the identification of current waveform incoming if an equivalent linear and balanced load is presented instead of the actual load. This load can be defined as the linear load that requires a fundamental frequency active power equal to the fundamental frequency active power actually fluxing by PCC. Thus, the equivalent balance and linear load is an ideal load. It requires a distorted current but it is not the responsible of the distortion.

In order to model the three-phase balanced linear ideal load, three identical R-L branches have been considered. By means of the evaluation of parameters R and L, the part of the load that represents the equivalent ideal load can be identified. So, from the consumer side, it is always possible the estimation of the part of load in passive elements which does not affect the distortion. This part of the actual load requires a balanced and linear current which constitute an ideal current and represents an only part of the total current fluxing through PCC. If ideal

current is almost total current, the load is not responsible of distortion problems.

Equivalent balanced and linear load parameters R and L are estimated in phase A according to the procedure indicated from now on. The same method can be applied to phases B and C. If phase A equivalent linear impedance is design by  $Z_{1A}$ , the R-L series circuit at fundamental frequency is:

$$\begin{aligned} |Z_{1A}| &= \frac{V_{1A}}{I_{1A}} \\ |Z_{1A}| &= |\theta_{1A} - \phi_{1A}| = \varphi_{1A} \end{aligned} \quad (6)$$

where  $V_{1A}$  and  $I_{1A}$  are voltage and current fundamental frequency rms values, respectively, in PCC, and  $\theta_{1A}$  and  $\phi_{1A}$  are those magnitude phases. So:

$$\begin{aligned} R_A &= |Z_{1A}| \cos \varphi_{1A} \\ X_{1A} &= |Z_{1A}| \sin \varphi_{1A} \\ L_A &= \frac{X_{1A}}{2\pi f_1} \end{aligned} \quad (7)$$

where  $X_{1A}$  represents reactance of combination series R-L at fundamental frequency,  $f_1$  and  $R_A$  and  $L_A$  are the corresponding parameters. Reactance values to voltage harmonic components are:

$$X_{kA} = 2\pi k f_1 L_A, \quad k = 1, 2, \dots, n \quad (8)$$

Without considering skin effect and supposing  $R_A$  independent on frequency, it is:

$$\begin{aligned} |Z_{kA}| &= \sqrt{R_A^2 + X_{kA}^2} \\ \varphi_{kA} &= \tan^{-1} \frac{X_{kA}}{R_A}, \quad k = 1, 2, \dots, n \end{aligned} \quad (9)$$

where n represents the harmonic voltage last order. Current consumed by the ideal linear load in phase A is:

$$i_{LA}(t) = \sum_{k=1}^n \frac{V_{kA}}{|Z_{kA}|} \sqrt{2} \sin(2\pi k f_1 t + (\theta_{kA} - \varphi_{kA})) \quad (10)$$

This is the equivalent linear current and the supply system is the only responsible of its distortion. The difference between measured current and calculated ideal current is defined as non-linear current:

$$i_{nLA}(t) = i_A(t) - i_{LA}(t) \quad (11)$$

The non linear load measures how much the actual load in phase A differs from the ideal in terms of harmonic distortion. Thus, an index of non-linear current is defined which supplies reliable information about distortion caused by the consumer:

$$NL = \frac{I_{nLA}}{I_A} 100 \quad (12)$$

### 3. Analysis of a practical case

Harmonic powers and harmonic distortion valuation indices introduced in previous section have been applied to the system presented in figure 3. It is a system constituted by three loads supplied by a sinusoidal voltage source. The first one is a resistive load. The other two consist of three-phase rectifiers with an impedance in the continuous side: a capacitive one in one case, and an inductive impedance in the other one.

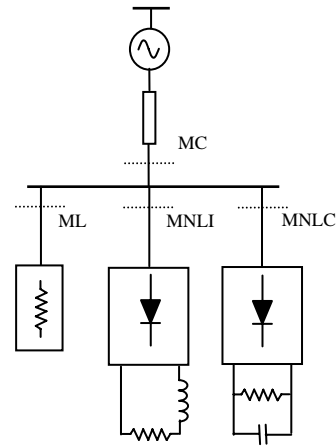

Fig. 3. Studied system configuration

Table I includes the most relevant harmonics powers in the four points of measurement with concrete source and load parameter values: the point of common coupling PCC, MC, the input to the linear load, ML, the input to the non-linear capacitive load, MNLC and the input to the non-linear inductive load, MNLI, figure 3. This table includes the values of total, P, fundamental,  $P_1$ , and harmonic, HP, active power in the four points of measurement. Total active power in MC is 6887.1 W according to power flux direction from source to consumer. It is due to the fact that some order harmonic powers are positive and its absolute value is higher than those corresponding to negative harmonic powers. If there was an only linear load connected in M, all the harmonic power would be positive. It is proved in point ML where linear load is connected and where active power is positive in the sense from source to load. If there was an only non-linear load connected in MC, all the harmonic power would be negative. The fact that there are two different non-linear loads connected in MC modifies the situation. The measures had in MC do not allow the identification of the distortion source (net side or consumer side). The situation is shown in points MNLC and MNLI where non-linear capacitive and inductive loads are connected, respectively. Harmonic power is -29.77 W in the first point and -2.02 W in the second. Both are negative in the system studied, corresponding to non-linear loads. However, it does not allow generalize the rule as can be seen later. In general, the active power flux direction method, when there are

more than one distortion source, establishes the predominant power for each harmonic according to opposite directions in the measurement point.

Table II includes the calculation of the distortion indices presented in previous section in the four points of measurement in the system. The indices calculated are voltage total harmonic distortion VTHD, current total harmonic distortion CTHD, harmonic phase index HPI, non collinear index NC and non-linear current index NL.

HPI index measures the relation of predominant current values in measurement point, table II. HPI indices in the four points of measurement show predominant currents in consumer-source direction. It looks a suitable index to evaluate the contribution of each load. In addition, table II includes VTHD, CTHD, NC and NL indices values. The four indices present consequent values: between 21.8 and 27.6 in MC, between 5.4 and 7.8 in ML, between 37 and 42.6 in MNLC and between 22 and 23.6 in MNLI.

Table I

	MC	ML	MNLC	MNLI
<b>P</b>	6887.1	2274.29	3867.69	590.8
<b>P1</b>	6905.2	2261.55	3897.46	592.8
<b>HP</b>	-18.06	12.74	-29.77	-2.02
<b>P2</b>	0.01	0	0.01	0
<b>P3</b>	-0.79	0.05	-0.41	-1.07
<b>P4</b>	0	0	0	0
<b>P5</b>	-13.28	7.22	-21.07	-0.91
<b>P6</b>	0	0	0	0
<b>P7</b>	-1.76	1.23	-2.97	0.03
<b>P8</b>	0	0	0	0
<b>P9</b>	-0.03	0.01	-0.05	-0.02
<b>P10</b>	0	0	0	0
<b>P11</b>	-0.84	1.38	-1.74	0.05
<b>P12</b>	0	0	0	0
<b>P13</b>	-0.22	0.19	-0.41	0.06

Table II

	VTHD	CTHD	HPI	NC	NL
<b>MC</b>	7.9	21.8	22.1	27.6	25.8
<b>ML</b>	7.6	7.7	1.1	7.8	5.4
<b>MNLC</b>	8.2	37	39.7	42.6	41.1
<b>MNLI</b>	7.7	22	22.2	23.6	22.1

Tables III and IV include the results corresponding to the same system whose voltage THD before the source impedance is now 14.8%. In this case the net Thevenin voltage is not sinusoidal but odd order harmonics have been included. Harmonic power HP is positive in linear and non-linear inductive loads and negative in non-linear capacitive load and PCC. It shows that, as was said earlier, the active power flux direction method, when there are more than one distortion source, only establishes the predominant power for each harmonic. In addition, it can be seen that index HPI presents values consequent with the corresponding to the before situation, table IV. It identifies the load level of linearity. In the case of NC and NL indices, they look too sensitive

to the voltage distortion. So, in the case of linear load (ML in the system studied), CTHD, NC and NL present a higher values when the source voltage is distorted than when it is sinusoidal. Thus, they show little stability with variations in net conditions.

Table III

	MC	ML	MNLC	MNLI
<b>P</b>	5706.3	1670.08	3275.84	644.99
<b>P1</b>	5711.42	1612.68	3335.62	644.61
<b>HP</b>	-5.13	57.4	-59.78	0.39
<b>P2</b>	-0.24	0.04	0.33	-0.7
<b>P3</b>	8.96	7.5	0.19	1.57
<b>P4</b>	-0.05	0.01	-0.01	-0.05
<b>P5</b>	-8.54	31.14	-34.69	-0.17
<b>P6</b>	-0.01	0	-0.03	0.01
<b>P7</b>	-7.08	9.73	-16.82	-0.31
<b>P8</b>	0.01	0	0	0.01
<b>P9</b>	1.33	1.38	0.01	0.04
<b>P10</b>	-0.01	0.01	-0.04	-0.01
<b>P11</b>	-4.49	3.68	-8.31	-0.17
<b>P12</b>	0	0.02	-0.04	-0.01
<b>P13</b>	-0.17	1.81	-2.36	0.06

Table IV

	VTHD	ITHD	HPI	NC	NL
<b>MC</b>	18.1	17.3	16.9	29.8	26.6
<b>ML</b>	18.3	18.9	0.9	13.6	10.8
<b>MNLC</b>	18.3	30.7	31.6	43.9	40.7
<b>MNLI</b>	18.1	20.5	18.8	26.7	19.3

#### 4. Conclusions

The increase of distorted voltage and current waveforms in electric power systems has rise the necessity of determining the contribution to harmonic distortion of consumers connected to nets. The power flux direction method has been largely used to identify the location of harmonic sources. However, this method is not able to solve this task in all the situations. To solve this situation, alternative procedures have been introduced with the restriction of looking for a solution based on measuring only in PCC. These procedures have introduced new indices as HPI, NC and NL that have been compared in this paper. So, indices presented have been applied to a practical case with several supply conditions. Results establish the next conclusions:

1. The active power flux direction method is mainly affected by phases of both harmonic sources. However sources magnitudes are more important to detect distortion source than phases.
2. Non collinear current to voltage index, NC, is not useful from the practical point of view because it does not discriminate inductive and capacitive linear loads. In addition, it presents

low stability to variations in net distortion conditions.

3. Non-linear current index, NL, seems suitable to characterize the part of non-linear current from a distorted load. It presents less variation to changes in net voltage distortion than NC index although more than HPI index.
4. Harmonic phase index, HPI, solves the disadvantages underlined in the active power flux direction method, using in its definition current rms values in one or another direction in PCC. On the other hand it presents a suitable stability in front of changes in net parameters.

## References

- [1] A. Menchetti, R. Sasdelli, Measurement Problems in Power Quality Improvement, ETEP, vol. 4, No. 6, Nov/Dec, 1994.
- [2] P. H. Swart, M. J. Case, J. D. Van Wyk, On Techniques for Localization of Sources Producing Distorsion in Electric Power Networks, ETEP, vol. 4, No. 6 Nov/Dec 1994
- [3] P. H. Swart, J. D. Van Wyk, M. J. Case, On Techniques for Localization of Sources Producing Distorsion in Three-Phase Networks, ETEP, vol. 6, No. 6 Nov/Dec 1996.
- [4] A. Ferrero, A. Menchetti, R. Sasdelli, Measurement of the Electric Power Quality and Related Problems, ETEP, Vol. 6, No. 6, November/December 1996
- [5] P. Salmerón, F. J. Alcántara, Identificación de fuentes de distorsión en sistemas eléctricos de potencia, Energía, Nº2, Marzo/Abril, 2000.
- [6] L. Critaldi, A. Ferrero y S. Salicone. A Distributed System for Electric Power Quality Measurement. IEEE Transaction on instrumentation and Measurement, Vol. 51, No. 4, August 2002.
- [7] L. S. Czarnecki, T. Swietlicki, Powers in Nonsinusoidal Networks: Their Interpretation, Analysis, and Measurement, IEEE Trans. on Instr. and Measurement, Vol. 39, No. 2, April 1990.
- [8] Srinivasan, K. On Separating Customer and Supply Side Harmonic Contributions, IEEE Trans. on Power Delivery, vol. 11, No. 2, April 1996.
- [9] T. Tanaka, H. Akagi, A New Method of Harmonic Power Detection Based on the Instantaneous Active Power in Three-Phase Circuits IEEE Trans. on Power Delivery, Vol. 10, No. 4, October 1995
- [10] E. Alexander Eigeles. On the Assessment of Harmonic Pollution. IEEE Transactions on Power Delivery, Vol.10, No. 3, July 1995.
- [11] A. P. J. Rens y P.H. Swart. On Techniques for the Localisation of Multiple Distortion Sources in Three-Phase Networks: Time Domain Verification. ETEP Vol. 11, No. 5, September/October 2001.
- [12] G.T. Heydt. Identification of Hormonic Sources by a State Estimation Technique. IEEE Transations on Power Delivery, Vol. 4, No. 1, January 1989.
- [13] J.E. Farach, W.M. Grady y A. Arapostathis. An Optimal Procedure for Placing Sensors and Estimating the Locations of Harmonic Sources in Power Systems. IEEE Transactions on Power Delivery, Vol. 8, No. 3, July 1993.
- [14] Definitions for the measurement of electric power quantities under sinusoidal, nonsinusoidal, balanced, or unbalanced conditions, IEEE Std 1459-2000, January 2000.
- [15] W. Xu y Y. Liu. A Method for Determining Customer and Utility Harmonic Contributions at the Point of Common Coupling. IEEE Transactions on Power Delivery, Vol. 15, No. 2, April 2000
- [16] W. Xu, X. Liu y Y. Liu. An Investigation on the Validity of Power-Direction Method for Harmonic Source Determination. IEEE Transactions on Power Delivery, Vol. 18, No. 1, January 2003.
- [17] T. Pyzalski, R Lukomski y K. Wilkosz. Utilization of the Voltage Rate to Localization of Harmonic Sources in a Power System. IEEE MELECON 2004, May 12-15, Dubrovnik, Croatia.
- [18] E. Thunberg y L. Söder. A Norton Approach to Distribution Network Modeling for Harmonic Studies. IEEE Transation on Power Delivery, Vol. 14, No. 1, January 1999
- [19] D. Sharon, Power Factor Definitions and Power Transfer Quality in Nonsinusoidal Situations, IEEE Trans. on Instrumentation and Measurement, Vol. 45, No. 3, June 1996.
- [20] Ch. Chen, X. Liu, D. Koval, W. Xu y T. Tayjasant. Critical Impedance Method- A New Detecting HarmonicSources Method in Distribution Systems. IEEE Transactions on Power Delivery, Vol. 19, No. 1 January 2004.
- [21] J.P.V. Du Toit, J.H.C. Pretorius y W.A. Cronje. Non Linear Load Identification under Non-Sinusoidal Conditions. Sixth International Workshop on Power Definitions and Measurements under Non-Sinusoidal Conditions, Milano, October 13-15, 2003.
- [22] M. Tsukamoto, S. Ogawa, Y.Natsuda, Y. Minowa y S. Nishimura. Advanced Technology to Identify armonics Characteristics and Results of Mesasuring.
- [23] A. Dell'Aquila, M. Marinelli, V. G. Monopoli y P. Zanchetta. New Power-Quality Assessment Criteria for Supply Under Unbalanced and Nonsinusoidal Conditions. IEEE Transactions on Power Delivery, Vol. 19, No. 3, July 2004.
- [24] C. Muscas, Assessment of Electrical Power Quality: Indices for Identifying Disturbing Loads, ETEP, Vol. 8, No. 4, July/August 1998.
- [25] L.S. Czarnecki, Distortion Power in Systems with Nonsinusoidal Voltage, Proc. IEE, Vol. 139, Pt. B, No. 3, pp. 276-280, May 1992.